

Shell-Clad™ Exhibition System panel dimensions

All Octanorm, Melville spec Sodem and Opex spec Modul Classic* only

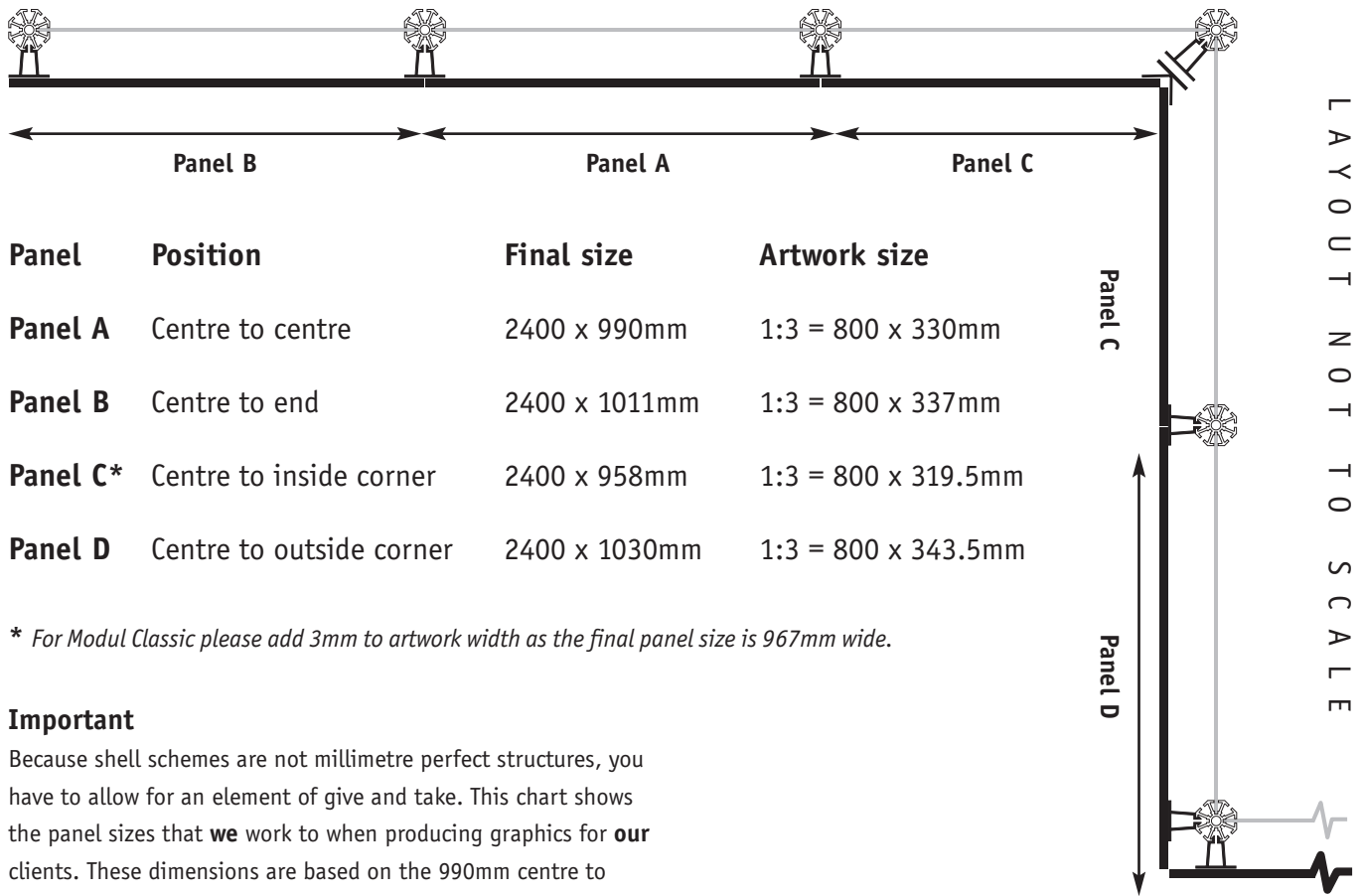

Panel	Position	Final size	Artwork size
Panel A	Centre to centre	2400 x 990mm	1:3 = 800 x 330mm
Panel B	Centre to end	2400 x 1011mm	1:3 = 800 x 337mm
Panel C*	Centre to inside corner	2400 x 958mm	1:3 = 800 x 319.5mm
Panel D	Centre to outside corner	2400 x 1030mm	1:3 = 800 x 343.5mm

* For Modul Classic please add 3mm to artwork width as the final panel size is 967mm wide.

Important

Because shell schemes are not millimetre perfect structures, you have to allow for an element of give and take. This chart shows the panel sizes that **we** work to when producing graphics for **our** clients. These dimensions are based on the 990mm centre to centre of an Octanorm stand. Please note that the centre to centre for a “Melville” Sodem stand is 992mm, however we choose to make all panels to the same size so that they fit both makes.

Please contact your Shell-Clad supplier to discuss panel sizes for other shell schemes.

Facia boards

If your shell scheme is fitted with a facia board, it will be necessary to cut out an ‘L’ shaped section from the front side wall panel where it meets the facia. This is best done on site. Please consider this cut in your design and always keep the off-cut incase you need to re-insert it at a later date.

Creating the artwork files

See page two of this document for a more detailed account of how to set up your files for print.

If you have any concerns, we recommend that you take your own measurements and work with these.

For further information, please contact your Shell-Clad™ supplier direct.

www.Shell-Clad.com

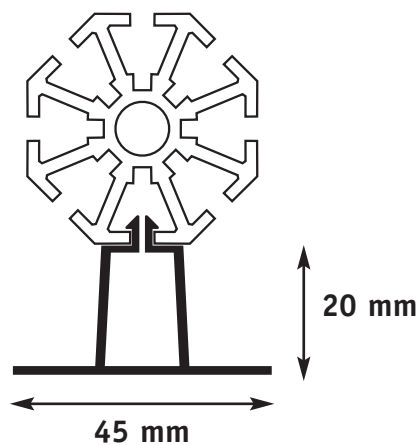

 **SHELL-CLAD™**
making exhibitions easy

Shell-Clad™ Exhibition Systems

Creating artwork files

File preparation

Files submitted for print should be professionally created and layed out in either Quark Xpress (Versions 5.0, 6.0 or 7.0) or Adobe InDesign (up to CS2), saved as native files and 'collected for output' (ie. with the linked graphics and fonts supplied). Files created in 'content design' applications are acceptable, but will be subject to additional preparation charges. Sufficient bleed must be added to all files to allow correct trimming.



Layout packages

Quark Xpressqrk Collect for output - ie. supply all fonts and images
 Adobe InDesignindd Include all linked images and fonts

Content design tools

Adobe Illustratorai or .eps Convert all fonts to outline and include any embedded image files
 Macromedia Freehandeps Convert all fonts to outline and include any embedded image files
 Adobe Photoshoptif Flatten all layers and supply as .tif files

Please supply colour hard copies and / or PDF proofs clearly marked with the relevant panel size.

NOTE

We do NOT accept Corel, Microsoft Word, PowerPoint, Excel or Adobe PDF documents for print.

Images

Image resolution should be given careful consideration - as the final shell scheme 'wall' is over two metres high and has to stand up to close inspection; as well as creating an impact when being viewed from a distance - the imagery is therefore all important. Files created in Adobe Photoshop should always be supplied in the CMYK colour mode and 100% in size at 100dpi or 300dpi for artwork 1/3rd in size.

To prevent pixelisation the imagery should never be subjected to any major scaling within the Photoshop programme. Never use .jpgs that have been 'grabbed' from websites as they are only designed for viewing on screen and will not withstand enlargement of this scale.

When creating files in Adobe Illustrator and Macromedia Freehand please make sure you are working in the 'CMYK preview mode'.

Layout

Your design should be set up as separate pages with at least 3mm bleed on all four edges. By setting up your artwork files as pages as opposed to spreads you can guarantee that the panels trim correctly and the final design will butt up as you expect it to.

If you have any concerns please contact your Shell-Clad supplier direct.

www.Shell-Clad.com

